

ANNEX 2 Installation document for alcohol interlocks

Product
 Supplier: Justec Shenzhen Co.,Ltd.
 Model: A3

1. Product Introduction

Table 1.1

No	Part Name and Description	Picture
1	A3 ECU (24 volt)	
2	A3 handset	
3	Handset clip fixture	
4	ECU to interlock handset cable	



5

Blow nozzle

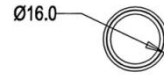
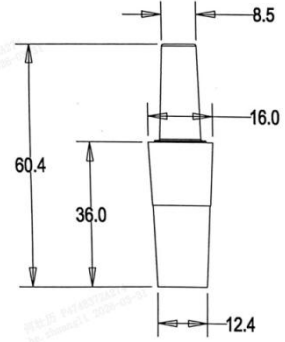

2. Product end connectors and vehicle end connectors pin definition

(1) Projection diagram of product end connectors: (ECU end harness)

BYD mating connector in accordance with the relevant requirements of the supplier of alcohol locks

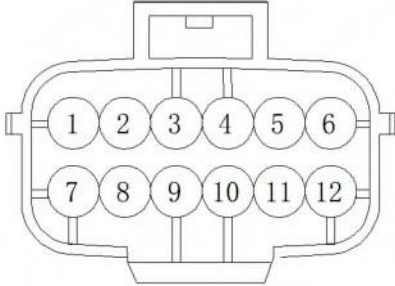

(2) Projection diagram of wire harness end connectors: (Distribution box end harness on vehicle, connect with ECU end connectors)

BYD mating connector in accordance with the relevant requirements of the supplier of alcohol locks

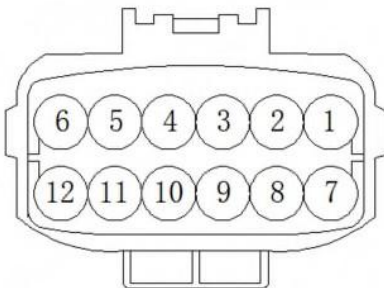



(3) Pin Definition
Table 2.1

Pin	ECU wiring harness color (Alcohol lock ECU comes with harness)	Product end harness color (BYD mating connector)	Port definition	Connection end (vehicle end connectors)	Connecti on end color	Steady state operating current	Power supply	Remark
1	Red	Red	24 volts, fused 10A	Distribution box	Red	7A	Constant electricity	Input 24V
2	Green	Green	Vehicle operation signal	Distribution box	Green	7A	ON position	Input 24V
3	/	/	/	/	/	/	/	/
4	/	/	/	/	/	/	/	/
5	Blue/Yellow	Gray	From ignition switch	Distribution box	Gray	7A	ON position	Input 24V
6	Blue	Blue	To starter	IBCM	Blue	/	/	/
7	Black	Black	Ground	Ground	Black	/	/	Ground
8	White	White	Electric start switch	Distribution box	White	7A	ON position	Input 24V
9	/	/	/	/	/	/	/	/
10	/	/	/	/	/	/	/	/
11	/	/	/	/	/	/	/	/
12	/	/	/	/	/	/	/	/

(4) System principle

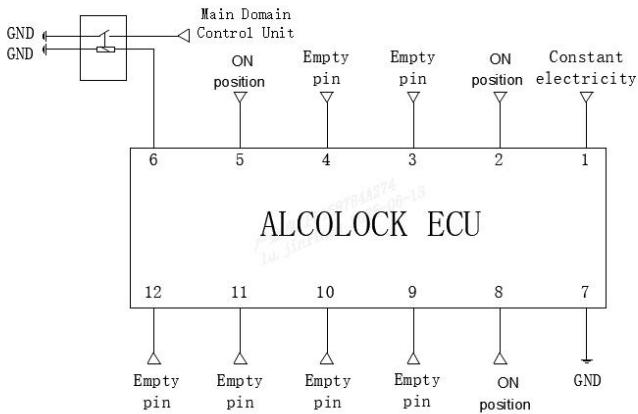

The detailed guide pin definition is shown in the table.
The 3/4/9/10/11/12 pins are empty pins, represents no need to connect with any product.

1. Product installation

The handset is installed in a place that the driver can reach and is not affected by other components of the vehicle, and is usually installed on the A pillar.

The handset is connected to the ECU by the product's built-in harness.

The handset is installed on the Handset clip fixture, AS shown in the figure.

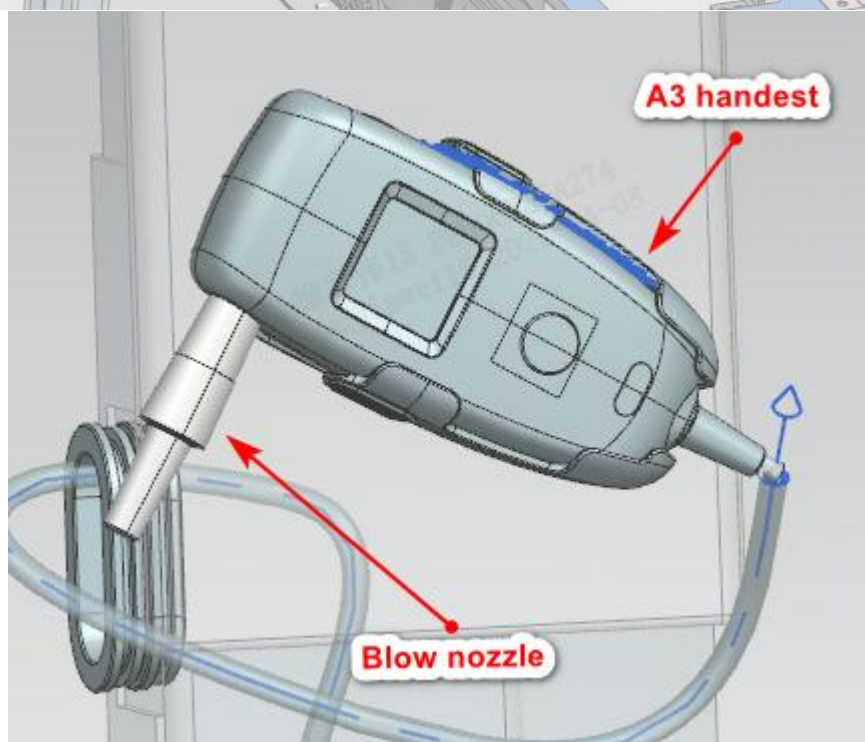
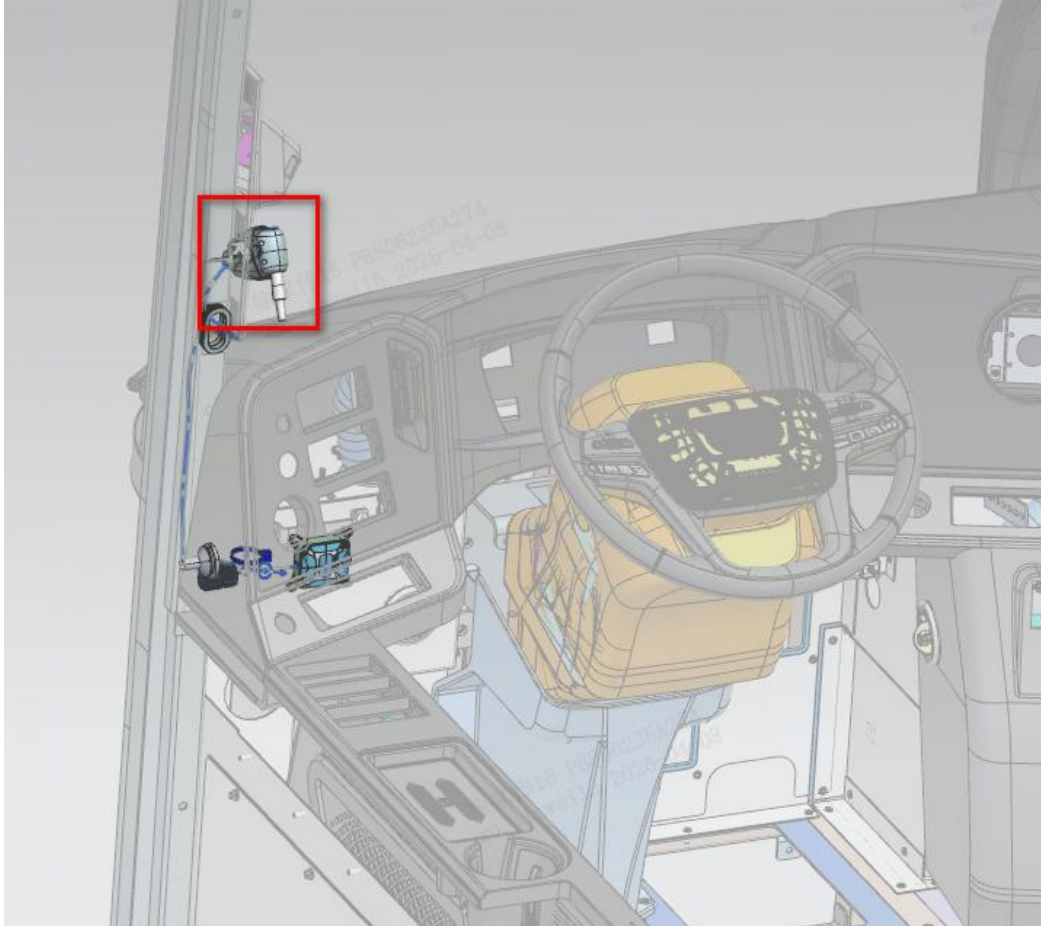

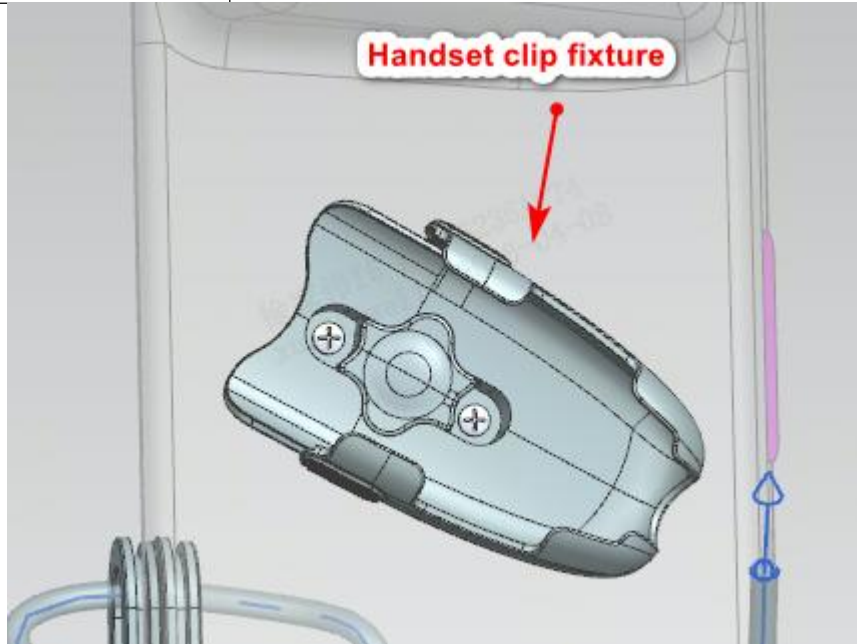

The ECU is concealed and installed below the instrument panel. The ECU harness is connected to the vehicle harness.

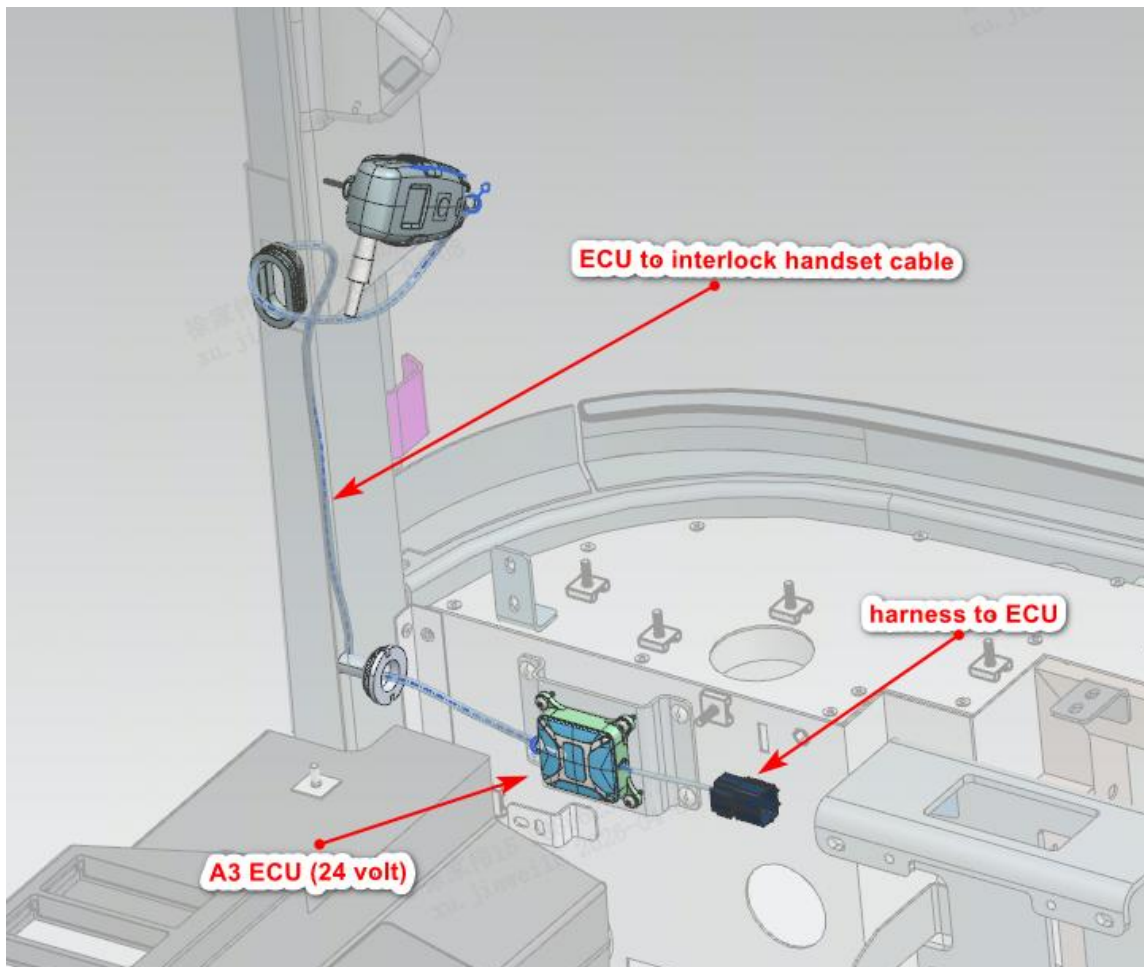

Low Voltage Distribution Box Lead-in Harness Connector (reserved on vehicle) is placed under the sleeper, detailed on the rear side of the Alcohol Locking ECU, visible when opening the sleeper.



2. Product function

Before starting a vehicle equipped with the alcohol lock device, the driver must undergo an alcohol test. The vehicle can only be started when the measured alcohol concentration is below the set limit value. (Attention: The device is not a safety device and cannot replace the anti-theft locking device)
The alcohol lock device only interferes with vehicle movement before the vehicle starts and does not affect the vehicle in motion.

3. Product working principle

Alcohol locks is prohibited from shifting gears. Only after the alcohol blowing test and the alcohol lock output high level gives IBCM, IBCM to collect high level signals and sends "the alcohol content normal state", the vehicle can be allowed to start, in other cases the alcohol lock does not output the high level, which is kept by IBCM to send "alcohol content state - excessive or unenabled" message, so that the vehicle can not be able to drive.

EN 50436-7:2016 Annex C 3B: Pseudo-digital installation.

4. Functional testing process

Table 6.1

No	Operation Steps	Implementation Results
1	when the vehicle is in OFF gear, press and hold the alcohol lock button, the vehicle is powered on, the alcohol lock is on, then release the button, and the alcohol lock will enter the language setting interface. At this time, click the next button, select the desired language and press the button for a long time. The alcohol lock will reset.	The alcohol lock is switched to the required language.



2	<p>The on position and observe the page display of the handset when you are ready to perform the breath test; the warm-up time is longer in the colder temperature. Note: Do not store the outhpiece to be used in a cold area. This will cause the mouthpiece to condense and increase moisture into the handset.</p>	<p>The page displays that blowing for 5 seconds indicates that blowing can be started, and reminds that blowing for 5 seconds is required.</p>
3	<p>In ON position, the page displays that the nozzle is inserted after blowing for 5 seconds. Blow into the mouthpiece continuously and moderately for more than 5 seconds, listen to the sound of exhalation flow at the same time, observe the page display of the handset, and stop blowing after hearing the sound of "click".</p>	<p>After the analysis, the page shows that the vehicle has passed the test. The vehicle can be put into gear. Note: It needs to be started within 5 minutes. Note: If the page shows that the air blowing is insufficient, it will remind you that you need to blow for a longer time and with a greater force; you can press the button to try again.</p>
4	<p>The blowing is successful, and the vehicle stops after the gear is engaged: 1. The vehicle stops for no more than 30 minutes; 2. The vehicle stops for more than 30 minutes.</p>	<p>1, the page shows the start cycle and countdown: it means that there is no need to repeat the breath test, and the vehicle can be driven in gear; 2. The page shows that air blowing lasts for 5 seconds, and it is necessary to blow again. After the air blowing passes, the vehicle can be driven in gear;</p>
5	<p>If the alcohol lock blowing test is not carried out, or the blowing test is not qualified.</p>	<p>The vehicle cannot be driven in gear.</p>

5. Installation steps

Table 7.1

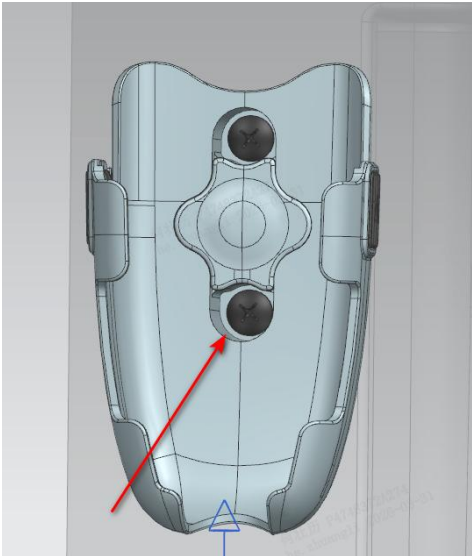
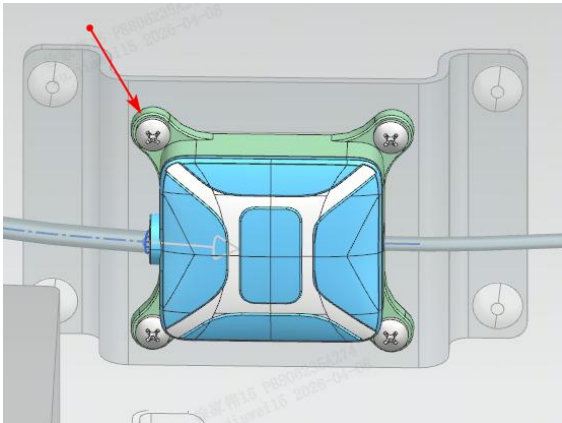
No	Products	Installation Location/Photo	Fasteners	Number of fasteners
1	Alcohol Lock Parts	 <p>Figure 7.1</p> <p>1.1 Secure the handset bracket to the post with two Phillips pan head screws.</p>	Cross recessed pan head tapping screw	2
		 <p>Figure 7.2</p> <p>1.2 Fix the alcohol lock ECU on the bracket with 4 cross recessed pan head self-tapping screws.</p>	Cross recessed pan head tapping screw	4

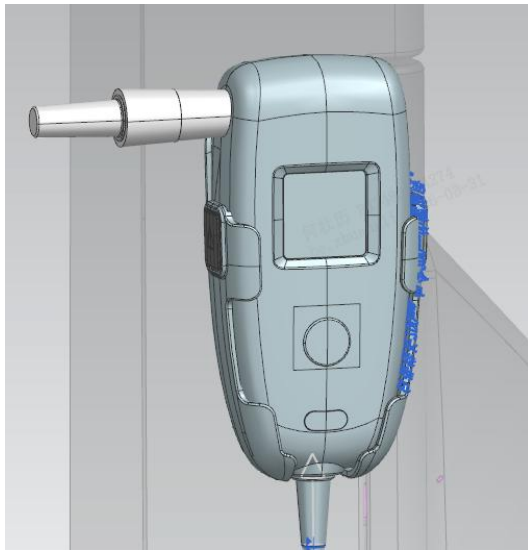

Figure 7.3

1.3 Attach the handset to the Handset clip fixture.

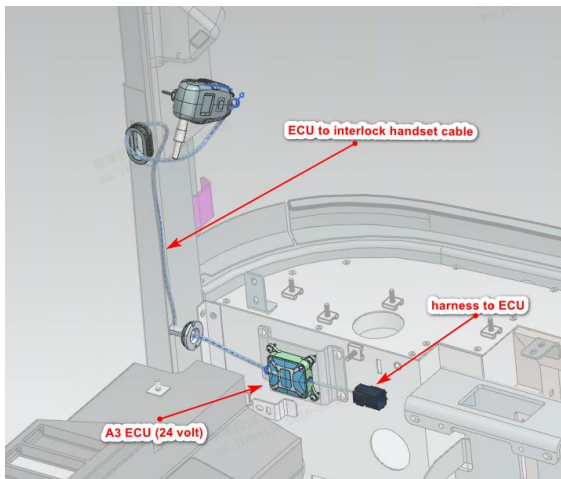

Figure 7.4

2.1 The approximate location of the Alcohol Lock ECU harness is shown in the figure, and it is fixed along the instrument panel wiring harness by tie-wrap and sponge tape.

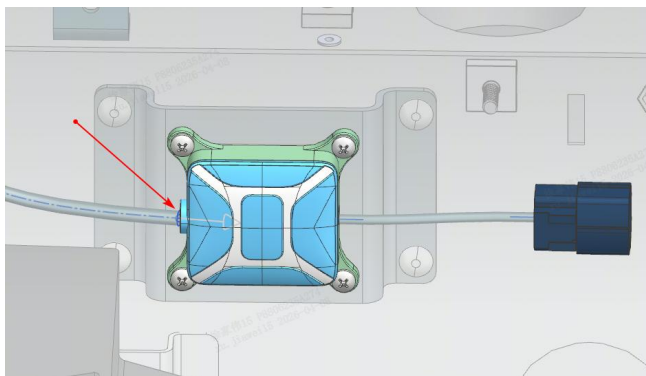

Figure 7.5

2.2 Alcohol Lock ECU harness and handset spiral harness mated in the location shown.

2

Alcohol
Lock
Parts
Harness

/

/

/

/

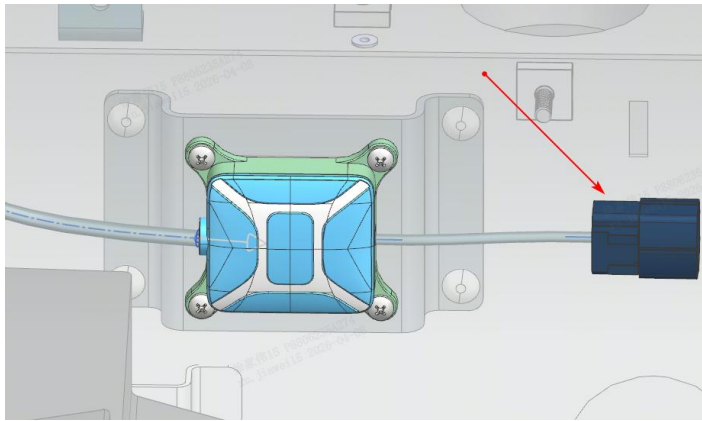

Figure 7.6

2.3 Connect product end connectors to Low Voltage Distribution Box Lead-in Harness Connectors, Installation is complete.